

A SEM Model in Assessing the Effect of Convergent, Divergent and Logical Thinking on Students' Understanding of Chemical Phenomena

D. STAMOVLASIS*, N. KYPRAIOS†, G. PAPAGEORGIU‡

ABSTRACT: In this study, structural equation modeling (SEM) is applied to an instrument assessing students' understanding of chemical change. The instrument comprised items on understanding the structure of substances, chemical changes and their interpretation. The structural relationships among particular groups of items are investigated and analyzed using confirmatory procedures. In addition, three psychometric cognitive variables, namely logical, convergent and divergent thinking are involved in the SEM analysis and their effects on students' performance estimated. Specifically, three models are tested: a confirmatory factor model, a multiple-indicator multiple-cause (MIMIC) model and path analysis. The SEM analysis showed that the cognitive variables, along with students' achievements in understanding the structure of substances and their changes, sufficiently explained students' ability to interpret chemical phenomena, providing additionally their direct and indirect effects. The theoretical analysis and the interpretation of the results contributed significantly to an understanding about the role of the above individual differences in learning secondary school chemistry. Implications for science education are also discussed.

KEY WORDS: Confirmatory factor model, MIMIC model, path analysis, logical thinking, convergent thinking, divergent thinking.

INTRODUCTION

Research on students' understanding of chemical change, carried out in a variety of contexts, focused mainly on difficulties originated from the subject matter itself, such as the particulate nature of matter. In some cases, the effect of individual differences on such a fundamental theme was studied (e.g. Stamovlasis & Papageorgiou, 2012), which however needed further support and development. The study of individual differences was important in science teaching, because it revealed the mental resources involved in learning specific domains and could relate them to persistent students' difficulties. For instance, students' inability to make connections between macro and micro levels, which was seen as a

* Corresponding Author: Aristotle University of Thessaloniki, Greece, stadi@edlit.auth.gr

† Democritus University of Thrace, Greece

‡ Democritus University of Thrace, Greece

core issue in chemistry education, might be due to their deficiency in formal reason and divergent thinking. Thus, knowing the origin of certain cognitive obstacles was certainly a valuable asset for teachers and those who were involved in curriculum development (see section on implications). The role of cognitive or psychometric factors on learners' understanding of chemical change was seen as a complex matter that might involve direct and/or indirect effects and interactions with the prerequisite knowledge as well. Given the methodological limitations of the common statistical approaches (e.g. correlational analysis), it was expected that rigorous statistical methods were needed to establish research findings. Ergo, in the present paper, an attempt was made to explore the effect of selected cognitive variables on students' competence in understanding and explaining chemical changes, using structural equation modeling (SEM). In a first step, the dimensions of understanding chemical changes were proposed via confirmatory analysis, and via SEM models on the effects of three cognitive variables, such as, convergent, divergent and logical thinking were portrayed related to understanding chemical changes.

Rationale and Research Questions

The present study focuses on conceptual understanding in chemistry. A deeper understanding of this matter and interpreting chemical phenomena requires on the one hand, a prerequisite knowledge of the structure of substances and an understanding of their potential changes, and on the other hand, the operation of certain mental resources involving in cognitive tasks. The effect of psychometric variables associated with these mental resources is established in science education research by implementing various methods, such as correlation analysis, multiple linear regression and logistic regression. Since the complexity of this research area demands a methodical investigation, structural equation modeling (SEM) is selected as a suitable modeling approach to further analyze the effect of contributing components on students' performance.

The aim of the present study is to reveal the structural relationship among variables constituting students' competence in explaining chemical phenomena and cognitive variables affecting their performance. In this context, three models are tested:

- First, a confirmatory factor model is applied in order to verify a hypothesized three-factor model on understanding chemical phenomena. The three factors are:
 - understanding the structure of substances (*Structure*),
 - understanding the transformations taking place in a chemical reaction (*Change*) and
 - interpreting the chemical changes (*Interpretation*).

- Second, a multi-indicator multi-cause (MIMIC) model is applied to explain students' performance by 'latent' and 'observed' variables simultaneously.
- Third, a path analysis, where the contributed components are used as observed variables, is implemented to demonstrate any direct and indirect predictor effect on students' achievement scores.

By using the above analyses, the main hypothesis investigated in this study is that students' knowledge of chemical phenomena is affected by the following three cognitive variables: (a) logical thinking, (b) convergent thinking and (c) divergent thinking.

In addition, a further hypothesis is that students' understanding of the structure of substances (*Structure*) and its transformations taking place (*Change*) is also tested in interpreting chemical changes, along with the psychometric variables affecting their competence in interpreting the chemical changes (*Interpretation*).

Besides the above, the present study aims to demonstrate the usefulness of the implementation of advanced statistical methods, such as SEM, in elucidating important issues and research questions in science education.

REVIEW OF RELEVANT LITERATURE

Students' understanding of chemical phenomena

Research in chemistry education has demonstrated through numerous findings, students have difficulties in attaining scientific knowledge related to chemical phenomena. A deep understanding of chemical change seems to be quite difficult in a wide range of school grades, from students of primary education to university students. Basically, it seems the difficulties originate from an inherent eccentricity of chemistry; it demands three levels of understanding simultaneously, that is, the macro, the micro and the symbolic levels (Johnstone & Al-Naeme, 1995). These difficulties have been explored extensively in the literature, in relation to these levels of understanding.

The nature and the degree of difficulty vary with the school grade and age in general. Young students hardly grasp the idea of chemical change, even for those of the higher grades of primary education (e.g. 5th, 6th grades). It seems they cannot understand changes in the structure of substances. This is mainly due to a lack of ability to think at the microscopic level. Thus, they cannot interpret such phenomena (Papageorgiou et al., 2010). Thus, it seems students of this age usually identify chemical change as procedures of mixing substances rather than as interactions between them. Although such misconceptions have also been found at higher grades e.g. at ages from 12 to 18 (e.g. Ben-Zvi,

Nylon & Silberstein, 1987; Boo & Watson, 2001; Johnson, 2002; Talanquer, 2008), generally, secondary education students seem to adequately understand chemical changes, since they demonstrate, to a certain degree, the capability to work at the microscopic level. For example, Solsona et al. (2003), investigating the understanding of a chemical change by students aged 17-18, identifies four different conceptual profiles, namely “incoherent,” “kitchen,” “meccano” and “interactive.” The latter, “interactive” profile, which comprise 8% of the sample, corresponds to a satisfying level of explanations, providing relevant examples, global coherence of the text and ultimately a clear evidence supporting the understanding of chemical change. However, a number of misconceptions are recorded, since the majority of the students can only operate at the microscopic level (“meccano”), or at the macroscopic level (“kitchen”), making it uncertain whether the connection between the two levels is achieved. On the other hand, a number of students present an “incoherent” behaviour, indicating an absence of any elementary comprehension. One can find students’ profiles, such as the above even in tertiary education, when the whole situation does not radically change. Considerable misconceptions remain and the percentage of university students who provide satisfying explanations for chemical phenomena is also found to be significantly low (Ahtee & Varjola, 1998; Stains & Talanquer, 2008).

Thus, the inability to operate simultaneously at both micro- and macro levels appears to be a crucial factor contributing to students’ failure to understand chemical phenomena and it seems to operate across different ages. Even in tertiary education, students’ abilities to connect micro- and macro- levels are limited and they frequently support their relevant explanations using phenomenological characteristics (Stains & Talanquer, 2008).

Furthermore, a determining step towards understanding chemical change is to connect the structure of the substances involved in the phenomenon with their properties. A lack of such a connection leads to an insufficient understanding of the nature of substances, which inhibits any interpretation of their change of properties during a chemical reaction. As a result, students often fail to make the distinction between chemical and physical phenomena (Abraham, Grzybowski, Renner & Marek, 1992) and their main criterion for categorizing a phenomenon as chemical or physical is its irreversibility (Kingir et al., 2013).

Moreover, specific aspects of a chemical reaction under investigation are fundamental for students’ knowledge attainment of chemical changes. For instance, the generation of a gas, especially in oxidation reactions, introduces further challenges related to the grasping of the origin of new substances and interpreting the observable changes. This has been evident in the majority of research investigating phenomena, such as combustion

(BouJaoude, 1991; Brosnan & Reynolds, 2001; Johnson, 2002; Calik & Ayas, 2005), formation of iron rust and iron sulfide (Brosnan & Reynolds, 2001; Solsona et al., 2003) and copper oxidation (Johnson, 2000). In all the above studies, diversity in students' responses is found, leading to profiles corresponding to different levels of understanding. For example, Johnson (2002), in investigating students' understanding of a burning candle, identifies six different categories of responses, which demonstrate a successive progression - from a simple consideration of the candle as an object and an absence of any alteration in the amount of wax during the phenomenon - to a recognition of the phenomenon as evaporation and finally - to a recognition of the interaction of wax with oxygen despite possible misconceptions concerning the structure of wax. In the same study, although the analysis of students' responses on copper oxidation has a different pattern, the results are analogous, showing again the students' limited comprehension of chemical phenomena.

Dimensions in students' understanding of chemical phenomena

Taking into account research evidence and generally a relevant literature review, one undoubtedly accepts that understanding chemical phenomena is a complex matter and involves a plethora of parameters. Thus, in order to launch our endeavour on this matter, an attempt is made, first to answer the epistemological question concerning the *dimensionality* of understanding chemical phenomena, which for the research methodology theory consists of a number of *latent variables*, each of which is measured by the corresponding *manifest variables*. The dimensionality is primarily a theory driven construction, which demands a further validation through a confirmatory statistical procedure. The latent variables of chemical knowledge are actually the axes, along which the competence of an individual learner related to this matter, can be measured. Thus, based on research and literature (e.g. Tsitsipis, Stamovlasis & Papageorgiou, 2010, 2012; Stamovlasis et al., 2013), it is proposed that students' knowledge progression related to chemical phenomena can be depicted through a three-factor model, consisting of the following dimensions:

- Understanding the structure of substances (*Structure*).
- Understanding the transformations taking place in a chemical reaction (*Change*).
- Interpreting the chemical changes (*Interpretation*).

The three latent variables/dimensions are not orthogonal, but they correlate with each other. Moreover, there is a hierarchical relationship among them; that is, the first represents a prerequisite knowledge for the second and both for the latter. These relations are very valuable in designing and developing teaching strategies and interventions.

Statistically, the variability of ‘*Interpretations*’ can be partially explained by ‘*Structure*’ and ‘*Changes*’, but still there is ample room for additional independent predictors, on which the main interest of the present research focuses.

Individual Differences

In chemistry education research, no matter which psychological theory of conceptual change is fostered, the focus is on intrinsic difficulties in the learning process. These undoubtedly originate from the inherent need to consider a chemical phenomenon at both, macro and micro/ sub microscopic levels, as is mentioned in the preceding sections. However, the ability of a learner to connect the two levels of complexity (micro and macro) is related with the operation of certain mental processes. These are reflected as individual differences associated with psychometric variables and are involved in the learning, reflection, or any other cognitive, process.

To this end, psychological theories working on individual differences, such as information processing models or neo-Piagetian theories, are suitable frameworks for explaining the variability of students’ performance on cognitive tasks. These are well established in science education research. The role of individual thinking differences such as logical thinking (formal reasoning ability), field-dependence/independence, convergence and /or divergence thinking, *M*-capacity and working memory capacity, have been investigated and reported in the relevant literature (Lawson, 1985; Chandran et al., 1987; Zeitoun, 1989; Johnstone & Al-Naeme, 1995; Niaz, 1996; Tsaparlis & Angelopoulos, 2000; Kang et al., 2005; Stamovlasis & Tsaparlis, 2005). Specifically, logical, field-dependence/independence and convergence/ divergence thinking are shown to play a significant role in a wide range of tasks related to learning science, and particularly in conceptual understanding of physical changes (Tsitsipis et al., 2010; 2012). Thus, such thinking are also sought as potential predictors in understanding chemical phenomena (Stamovlasis & Papageorgiou, 2012). A brief presentation of these cognitive variables follows.

Cognitive variables

Logical Thinking

Logical thinking (LTh) refers to the ability of an individual to use concrete and formal operational reasoning (Lawson, 1993). LTh is a Piagetian concept and includes proportional, combinational and probabilistic reasoning, as well as reasoning related to the isolation and control of variables such as conservation of weight, or displaced volume.

Numerous studies can be found in the literature reporting the correlation between LTh and students' performance in science e.g. (1982), Chiappetta and Russell (1982), Chandran et al. (1987), Zeitoun (1989), Niaz (1996), and BouJaoude et al. (2004).

Convergence/Divergence

Convergence (CONV) and divergence (DIV) are two distinct cognitive styles, rather than opposites (Heller, 2007), that are introduced as special aspects of intelligence. Convergence is the ability of an individual to focus on the one right answer in order to find the solution of a problem, whereas divergence is one's ability to respond flexibly and successfully to problems requiring the generation of several solutions (Child & Smithers, 1973). Divergent thinking is usually correlated with creativity and since Gretzels and Jackson (1962) has distinguished intelligence from creativity, most researchers believe that divergence is associated with creativity and convergence is associated with intelligence. In chemistry education research, students' achievement is found to be significantly associated with these psychometric variables (Danili & Reid, 2006).

Methodology

Participants

The participants of this study (N=374, where 52.1% male and 47.9% female) were students of 8th, 10th and 12th grades (aged 13, 15 and 17) of secondary public schools from the region of East Macedonia, Northern Greece. The students were of mixed abilities and socioeconomic background. In all schools, the same curriculum was followed throughout the school year and the same textbook was used in each one of the grades. Data were collected during one school year through paper-and-pencil tests about two months after the last lesson related to the chemical change topic. Students were always informed about the purpose of the study.

Measurements

All students were assessed on the three cognitive variables by means of corresponding tests that had been widely implemented in related studies. The test for chemical phenomena was also a paper-and-pencil instrument especially designed for the present study. Before the main study, a pilot study (N=77) was carried out in order to detect and correct possible errors and deficiencies in the instruments.

The instruments were as follows:

Logical Thinking (LTH): This instrument was the Lawson paper-and-pencil test of formal reasoning (Lawson, 1993). It took about 45-min and

consisted of 15 items involving the following: conservation of weight (one item), displaced volume (one item), and control of variables (four items), proportional reasoning (four items), combinational reasoning (two items) and probabilistic reasoning (three items). The students were also required to justify their answers. For the present sample, the Cronbach's alpha reliability coefficient was found to be 0.81.

Divergent Thinking (DIV): Divergence was measured by a six-item test designed by Bahar (1999). Each item constituted a mini test in itself, lasting for 2–5 min and asked students to:

- generate words with similar meaning to those given (test 1),
- construct up to four sentences using the words in the form as given (test 2),
- draw up to five different sketches relevant to the idea given (test 3),
- write as many aspects as possible that have a common trait (test 4),
- write as many words as possible that begin with one specific letter and end with another specific letter (test 5), and
- list all the ideas about a given topic (test 6).

This instrument was first used with Greek students by Danili and Reid (2006) and recently by Tsitsipis et al. (2010). A Cronbach's alpha reliability coefficient of 0.75 was obtained for the present study.

Convergent Thinking (CONV). Convergence was assessed by a five-item timed test, which was introduced recently by Hindal et al. (2008). The test was translated into Greek with modification to some words and ideas in order to fit a Greek idiom. Students were asked to answer each question separately in a total time of 20 minutes.

Test 1 asked students to:

- find two patterns that link to a group of words given (question 1),
- form two words from the letters given (question 2), and
- write and explain a number missing from three sequences given (question 3).

Test 2 asked students to read a topic and classify three main ideas in the diagram given. Test 3 asked students to pick out the different object from a group of four and explain the reason to select it. Test 4 asked students to write two things, which were perceived to be true for all four graphs given. Test 5 asked students to mark a route on a map given and describe the route to take in a few words. For the present sample, the Cronbach's alpha reliability coefficient was found to be 0.60.

Understanding of chemical phenomena: This variable was assessed by an instrument developed for the needs of the present study and was the same for all grades. The synthesis of iron sulfide from its components was chosen as the theme under examination. The instrument included a

number of pictures, which provided students with additional information needed. The instrument comprised 11 items, which could be grouped into three distinct tasks.

- Task 1 corresponds to understanding of the structure of the substances (*Structure*).
- Task 2 corresponds to a recognition of the change of substances (*Change*).
- Task 3 corresponds to an interpretation of the chemical changes (*Interpretations*).

A description of all tasks and items is shown in Appendix 1. The Cronbach's α reliability coefficient of the instrument was found to be 0.79.

To evaluate the chemistry test, a marking scheme based on a 4-stage Likert-type scale was used for each item. A score of "3" was assigned to completely correct responses (written answers or drawings) that included work at the sub-microscopic level according to what had been taught to a certain degree. A score of "2" was assigned to partially correct responses, a score of "1" to partially incorrect responses included misconceptions of any kind, while no responses or irrelevant responses were marked with "0". To the resulting ordinal scales, a multidimensional scaling was applied before they were introduced to SEM analyses.

RESULTS

The three analyses, i.e. the confirmatory factor analysis, the multi-indicator multi-cause (MIMIC) model and the path analysis, were conducted via LISREL8.8 structural equation modelling computer program (Bentler, 1998). The variables used as those 'observed' were the scores of the 11 items and the scores of the cognitive variables LTH, CONV and DIV. Table 1 presents the correlation matrix of the 14 observed variables used as the input in the LISREL program.

Three analyses were carried out: Confirmatory factor analysis; Multi-indicator multi-cause (MIMIC) model; and Path analysis.

The following indices were used as measures of goodness-of-fit:

1. Comparative fit index (CFI) was used as a focal index, since it has advantageous statistical properties, i.e. it has a standardized range, small sample variability and stability with various sample sizes (Jöreskog and Sörbom 1981; Bentler 1990). A value of CFI greater than 0.95 indicates an adequate model fit (Hu and Bentler, 1999).
2. A goodness-of-fit χ^2 .
3. A Standardized Root Mean-square Residual (SRMR).
4. Root Mean-Square Error of Approximation (RMSEA).

5. Non-Normed Fit Index (NNFI).
6. 6 Adjusted Goodness of Fit Index (AGFI).

Confirmatory factor analysis

The confirmatory factor model was used to verify the hypothesized three-factor model of understanding chemical phenomena, comprising the factors stated in the ‘rationale part’, i.e. understanding the structure of substances (*Structure*), understanding the transformations taking place in a chemical reaction (*Changes*) and interpreting the chemical changes (*Interpretations*).

The value of CFI was 0.99; The Standardized Root Mean-square Residual SRMR is 0.027; The Root Mean-Square Error of Approximation RMSEA is 0.026; The Non-Normed Fit Index NNFI is 0.99; The Adjusted Goodness of Fit Index AGFI is 0.96 (see Figure 1).

These indicate an adequate model fit.

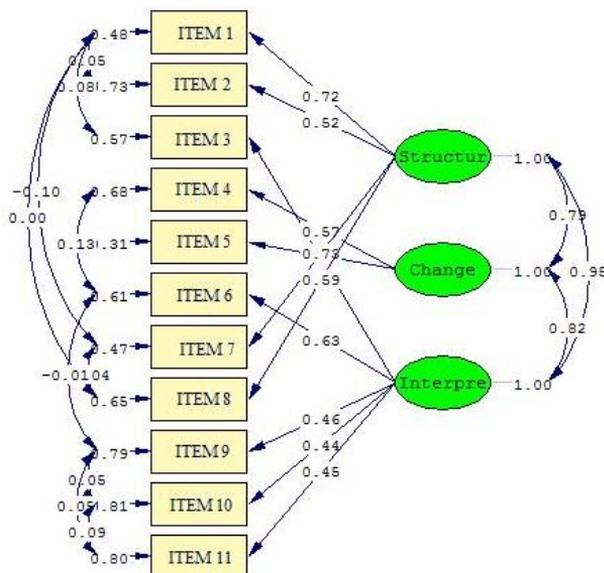

Figure 1. Confirmatory factor model for the three hypothesized dimensions of understating chemical phenomena: *Structure*, *Change* and *Interpretation* (shown as ‘Structur’, ‘Change’ and ‘Interpre’, respectively). An ellipse denote latent variables and a square, an observable variables. The model is statistically significant (goodness-of-fit $\chi^2 = 38.62$, $df = 31$, $p = 0.16$; RMSEA = 0.026).

A multiple-indicator multiple-cause (MIMIC) model

The Structural equation modelling involved the 11 observed variables (Table 1) and the 3 latent variables. *Structure*, *Change* and *Interpretation*

were measured as indicated by the above confirmatory factor model and consist the latent variables, which have relationships among them and with LTH, CONV and DIV. The latent variable ‘*Interpretation*’, which requires higher cognitive skills, could be examined as dependent variable affected by *Structure*, *Change* and the psychometric variables as well. These structural relations are examined in a multiple-indicator multiple-cause model (MIMIC), where latent variables are predicted by both latent and observed variables.

Figure 2 shows the MIMIC factor model. The value of CFI is 0.99; the goodness-of-fit $\chi^2 = 72.15$, $df = 59$, $p = 0.12$; the Standardized Root Mean-square Residual SRMR is 0.035; the Root Mean-Square Error of Approximation RMSEA is 0.024; the Non-Normed Fit Index NNFI is 0.99 and the Adjusted Goodness of Fit Index AGFI is 0.95. The about indicate an adequate model fit. Table 2 shows the structural equation coefficients, standard errors, t -values, error variances and R^2 s for SEM equation in the MIMIC model.

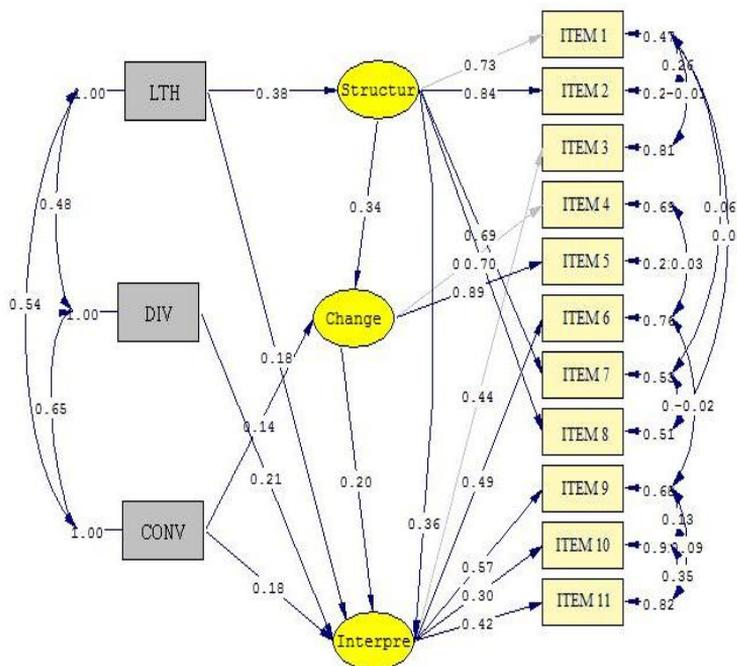

Figure 2. Structural equation modeling for the effect of the psychometric variables LTH, CONV and DIV on the three latent variables of students' understanding chemical phenomena: students' competence in *interpretation* of chemical phenomena (Interpre), understanding the *structure* of substances (Structur) and its *change* (Change). Ellipses denote latent variables and squares denote observable variables. The model is statistically significant (goodness-of-fit $\chi^2 = 72.15$, $df = 59$, $p = 0.12$; RMSEA = 0.024).

Table 1. Correlation matrix of the observed variables (LISREL input)

Variable	1	2	3	4	5	6	7	8	9	10	11	12	13
LTH	1												
DIV	.472**	1											
CONV	.537**	.550**	1										
ITEM 1	.236**	.196**	.185**	1									
ITEM 2	.278**	.205**	.233**	.841**	1								
ITEM 3	.244**	.253**	.205**	.183**	.223**	1							
ITEM 4	.082	.135**	.104*	.179**	.194**	.146**	1						
ITEM 5	.218**	.198**	.216**	.267**	.308**	.183**	.497**	1					
ITEM 6	.288**	.237**	.260**	.216**	.230**	.249**	.152**	.175**	1				
ITEM 7	.257**	.100	.194**	.549**	.544**	.163**	.112*	.201**	.158**	1			
ITEM 8	.252**	.142**	.186**	.499**	.570**	.174**	.126*	.197**	.165**	.735**	1		
ITEM 9	.321**	.301**	.273**	.212**	.202**	.209**	.165**	.210**	.248**	.171**	.234**	1	
ITEM 10	.083	.154**	.143**	.001	.032	.257**	.036	.143**	.192**	.099	.140**	.327**	1
ITEM 11	.162**	.208**	.197**	.203**	.255**	.235**	.133*	.253**	.173**	.201**	.201**	.339**	.477**

Table 2. Structural equation coefficients, standard errors, *t*-values, error variances and R²s, for SEM equation in the MIMIC model

Model		b	esd	t	R ²
Structure Understanding					.142
Predictor	<i>LTH</i>	.377	.062	6.04***	
	<i>Error Variance</i>	.858	.164	5.14***	
Understanding Change					
Predictors	<i>Structure</i>	.345	.095	3.65**	
	<i>CONV</i>	.143	.062	2.32*	
	<i>Error Variance</i>	.841	.201	4.18**	
Interpretations					.607
Predictor	<i>Structure</i>	.361	.085	3.66**	
	<i>Change</i>	.197	.079	2.48*	
	<i>LTH</i>	.185	.080	2.32*	
	<i>DIV</i>	.211	.082	2.89**	
	<i>CONV</i>	.183	.085	2.56*	
	<i>Error Variance</i>	.393	.143	2.75*	

* $p < .05$, ** $p < .01$, *** $p < .001$

Path analysis

Total scores of the variables *Structure*, *Change* and *Interpretation* were calculated by summing up the corresponding scores of the manifest variables and, along with the psychometric variables, introduced into path analysis. Figure 3 shows the Path model. The value of CFI is 1.00; the goodness-of-fit $\chi^2 = 4.22$, $df = 4$, $p = 0.36$; the Standardized Root Mean-square Residual SRMR is 0.022; the Root Mean-Square Error of Approximation RMSEA is 0.015; the Non-Normed Fit Index NNFI is 0.98 and the Adjusted Goodness of Fit Index AGFI is 0.98. These indicate an adequate model fit.

INTERPRETATION OF THE RESULTS AND DISCUSSION

Structural equation modelling provides an analytical portrait of the relations among the observed and latent variables involved in learning sciences and contributes to our understanding about students' knowledge on the matter under investigation. It facilitates the theoretical interpretation and the establishment of relations between aspects of the cognitive skills that are behind the psychometric measurements and the nature of mental tasks involved when learning this specific domain material.

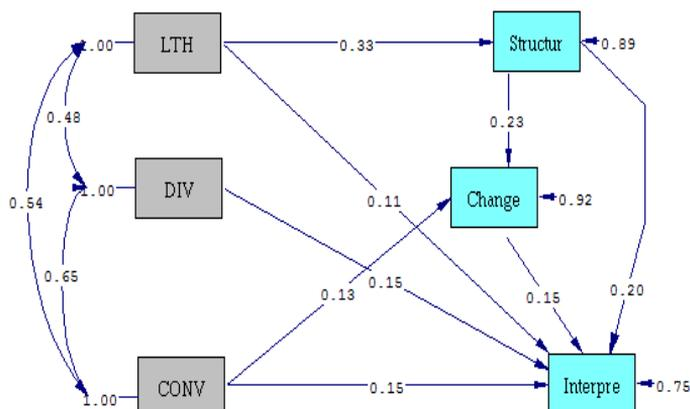

Figure 3. Path analysis of students' competence in *interpretation* of chemical phenomena (*Interpre*) as a function of their understanding the *structure* of substances (*Structur*), *change* (*Change*) and the psychometric variables LTH, CONV and DIV. The model is statistically significant (goodness-of-fit $\chi^2 = 4.22$, $df = 4$, $p = 0.36$; RMSEA = 0.015).

The confirmatory factor model supported the three dimensions of understanding chemical phenomena, proposed by the authors, which are based on previous empirical findings and literature review. It is important to stress at this point that items in cognitive task, such as those used in the present research, might not exclusively belong to one of the latent categories *Structure*, *Change* and *Interpretation*. That is, when a student provides interpretations of a phenomenon, it is unavoidable that, at least implicitly, a reference is made to *Structure* or *Change*. From a statistical point of view, the item loads on more than one latent factor. This is the case in item3, which initially was assigned to *Change*. However, the LISREL algorithm suggested that it should correspond to the *Interpretation* dimension.

The CFM analysis supports the initial hypothesis that *Structure*, *Change* and *Interpretation* are the latent variables that synthesize students' knowledge attainment of chemical phenomena; this three-factor model can be implemented with confidence in further development of any assessment system of students' knowledge on this matter.

The MIMIC model, which involves latent variables that are predicted by observed and latent variables, shows how the variables involved in predicting students' competence in interpreting chemical phenomena, are related to the dependent variable and to each other.

Figure 2 shows the relations that supported the main hypothesis of this study, i.e. that three cognitive variables (LTH, DIV and CONV) affect students' performance (the effect of FDI is discussed later). Apart from

the three cognitive predictors, logical thinking ability (LTH) is, by far, the best affecting by all latent variables, *Structure*, *Change* and *Interpretation*. The latter, which requires higher cognitive skills, can be examined as a dependent variable affected by *Structure* and *Change*, representing prerequisite knowledge.

Logical thinking ability (LTH) predicts all three, *Structure*, *Change* and *Interpretation* as depicted in Figures 2 and 3. LTH operations appear to be, along with the prerequisite knowledge necessary for providing interpretation of chemical changes, by all accounts a deeper understanding. These results are consistent with other findings in previous studies that report the supremacy of logical thinking as a predictor variable for science achievement (Chandran et al. 1987; Johnson & Lawson 1998; Kang et al., 2005). SEM analysis supports the hypothesis that a sufficient level of logical thinking is necessary for students to understand the nature of matter and its chemical changes. This is further support for the role of LTH in science education, demonstrated also with analogous methodological tools-SEM (Stamovlasis et al., 2012).

Divergent thinking (DIV) is also a significant predictor of students' understanding of chemical phenomena, and based on SEM results, it demonstrates its effect on the most demanding dimension, that of *Interpretation*. It appears that divergent students are better at understanding and interpreting chemical phenomena. The content of scientific material that the assessing instrument covered in this study involves a diversity of concepts, properties and models, which mostly require detailed descriptions in order to be understood when studied or taught. Therefore, it is reasonable to assume that linguistic skills may have played a major role in students' understanding of the relevant scientific topics. Linguistic skills, such as comprehension and interpreting of a scientific text, are considered to be of paramount importance for reasoning in science (Byrne et al. 1994). Students who show superiority in language are thought to be divergent thinkers (Hudson, 1966; Runco, 1986; Danili & Reid, 2006). Links between divergence and science has also been reported in the literature. As Hudson (1966) characteristically points out 'convergers' tended to choose the sciences, but 'divergers' who choose the sciences performed very well.

We remind here that divergent and convergent thinking are not mutually exclusive as they are two different dimensions corresponding to different mental resources and capabilities. CONV is found to affect understanding of *Change* and *Interpretation*. Understanding change in the structure of substances requires the need to focus on a particular aspect of structure, where mental resources related to convergence are expected to operate. Similarly, beside divergence and linguistic abilities, the interpretation of phenomena, up to a point, requires convergence for

certain attributes and processes that provide the necessary explanations of the phenomena in question.

Concluding, it is important to state that the hypotheses are well supported by the data. In the MIMIC model, R^2 is 0.61, while the corresponding R^2 in the reduced form equations is 0.42; that is, 42.0 % of the students' achievement variance is explained by the latent and observed variables, while all the related model-parameters are statistically significant (Schumacker & Lomax, 2010). Thus, we maintain that the findings of the present research are of paramount importance, because they shed light on the factors hindering students' understanding of chemical phenomena. On the other hand, the present study builds on the research area of conceptual change in this particular domain, where the individual differences, such as logical thinking and cognitive styles, have been ignored in research hypotheses over the last decades.

Implications for science education and research

The implications of the present research and findings concern undoubtedly all those who are involved in science education, i.e. teachers, stakeholders and researchers.

Chemistry and, in general science, teachers need to realize that learning difficulties in understanding chemical phenomena may originate from individual differences, such as those under examination. A chemistry instructor can help students with insufficient formal reasoning to overcome barriers and obstacles existing, due to their limited relevant ability, by applying appropriate teaching methods that make abstract concepts more accessible, even through use of concrete thinking. As also discussed elsewhere (Cantu & Herron, 1978; Howe & Durr, 1982; Zeitoun, 1984; Tsitsipis et al., 2012), these methods can include illustrations, diagrams and models that constitute more perceptible entities under study in order to pay attention to critical attributes of abstract concepts. Moreover, similar method may be employed to overcome difficulties due to the lack of diverging thinking, or restricted linguistic skills.

On the other hand, science curriculum designers needs also to be informed about all of the above and decide how to develop appropriate content in each grade, given that some of the individual differences, such as logical thinking (developmental level) evolve with age. Alternatively, they can use the means and the methods suggested above to overcome other learning obstacles. Generally, such a curriculum may start with a macroscopic study of the substances involved in a chemical change and then continue with the introduction of particle ideas, thus giving the opportunity to students to facilitate the structures of these substances (*Structure*) and to understand their changes (*Change*). According to the present findings, this progress can lead students to possible interpretations

of the chemical change (*Interpretation*). In addition, it needs to take place within an explanatory context (Danili & Reid, 2004) and in accordance with students' age. Although the latter, i.e. the most appropriate age for the corresponding study of chemical changes, is a matter of wider discussion, Johnson and Papageorgiou (2010), for instance, suggest that even young students can be involved in such a study following a progressive path, similar to that presented above (*Structure – Change – Interpretation*).

Moreover, it is very important for all the stakeholders to realize that the various cognitive styles, which determine the way a student approaches a learning task, suggest different learning strategies (Sternberg, 1997; Riding & Rayner, 1998). Furthermore, the message that 'individual-difference' research conveys to the science teachers, in a constructive teaching on chemical change and in any relevant science domain as well, is that no single correct way or teaching design may exist which appeals to all learners.

Last, but not least, research needs to extend the present findings on the effects of psychometric variables to various domains of science, completing the whole portrait of the effects of such individual differences on students' competence. This can impact on both students with high abilities and those with learning difficulties, providing them with the appropriate support. Moreover, apart from the particular findings and the research questions elucidated, the present study, even with its limitations, demonstrates the usefulness of SEM modelling in assessing and explaining students' achievements in science education research.

REFERENCES

- Abraham, M. R., Grzybowski, E.B., Renner, W.J., & Marek, E. A. (1992). Understandings and misunderstandings of eighth graders of five chemistry concepts found in textbooks. *Journal of Research of Science Teaching*, 29(2), 105-120.
- Ahtee, M., & Varjola, I. (1998). Students' understanding of chemical reaction. *International Journal of Science Education*, 20(3), 305-316.
- Al-Naeme, F. F. A. (1991). *The influence of various learning styles on practical problem-solving in chemistry in Scottish secondary schools*. Ph.D. thesis, University of Glasgow.
- Anderson, T. W. (1984). *An introduction to multivariate analysis* (2nd ed.). New York: Wiley.
- Andersson, B. (1990). Pupils' conceptions of matter and its transformations. *Studies in Science Education*, 18, 53-85.
- Bahar, M. (1999). *Investigation of biology students' cognitive structure through word association tests, mind maps and structural communication grids*. Ph.D. thesis, University of Glasgow.
- Bahar, M., & Hansell, M. (2000). The relationship between some psychological factors and their effects on the performance of grid questions and word

- association tests. *Educational Psychology: An International Journal of Experimental Educational Psychology*, 20, 349-363.
- Bennett, S. N., (1973). Divergent thinking abilities—a validation study. *The British Journal of Educational Psychology*, 43, 1-7.
- Bentler, P.M. 1990. Comparative fit indexes in structural models. *Psychological Bulletin* 107, no. 2: 238–246.
- Ben-Zvi, R., Nylon, B. S., & Silberstein, J. (1987). Students' visualization of a chemical reaction. *Education in Chemistry*, 24, 177 – 120.
- Boo, H.K., & Watson, J.R. (2001). Progression in high school students' (aged 16-18) conceptualizations about chemical reactions in solution. *Science Education*, 85(5), 568-585.
- BouJaoude, S. B. (1991). A study of the nature of students' understanding about the concept of burning. *Journal of Research in Science Teaching*, 28(8), 689-704.
- BouJaoude, S., Salloum, S., & Abd-El-Khalick, F. (2004). Relationships between selective cognitive variables and students' ability to solve chemistry problems. *International Journal of Science Education*, 26(1), 63-84.
- Brosnan, T., & Reynolds, Y. (2001). Student's explanations of chemical phenomena: macro and micro differences. *Research in Science & Technological Education*, 19(1), 69-78.
- Bryman, A., & Cramer, D. (1990). *Quantitative data analysis for social scientists*. London: Routledge.
- Byrne, M., Johnstone, A., & Pope, A., (1994). Reasoning in science: a language problem revealed? *School Science Review*, 75(272), 103-107.
- Cantu, L. L., & Herron, J. D., (1978). Concrete and formal Piagetian stages and science concept attainment. *Journal of Research in Science Teaching*, 15, 413-419.
- Chandran, S., Treagust, D. F., & Tobin, K. (1987). The role of cognitive factors in chemistry achievement. *Journal of Research in Science Teaching*, 24(2), 145-160.
- Chiappetta, E., L. & Russell, J., M. (1982). The relationship among logical thinking, problem solving instruction, and knowledge and application of earth science subject matter. *Science Education*, 66(1), 85-93.
- Child, D., & Smithers, A., (1973). An attempted validation of the Joyce-Hudson scale of convergence and divergence. *British Journal of Educational Psychology*, 43, 57-61.
- Costu, B., Ayas, A., Niaz, M., Unal, S., & Calik, M. (2007). Facilitating Conceptual Change in Students' Understanding of Boiling Concept. *Journal of Science Education and Technology*, 16, 524-536.
- Calik, M., & Ayas, A. (2005). A comparison of level of understanding of eighth-grade students and science student teachers related to selected chemistry concepts. *Journal of Research of Science Teaching*, 42(6), 638-667.
- Cantu, L. L., & Herron, J. D. (1978). Concrete and formal Piagetian stages and science concept attainment. *Journal of Research in Science Teaching*, 15, 413-419.
- Chandran, S., Treagust, D. F., & Tobin, K. (1987). The role of cognitive factors in chemistry achievement. *Journal of Research in Science Teaching*, 24(2), 145-160.

- Chandrasegaran, A. L., Treagust, D. F., & Mocerino, M. (2008). An evaluation of a teaching intervention to promote students' ability to use multiple levels of representation when describing and explaining chemical reactions. *Research in Science Education*, 38(2), 237-248.
- Chiappetta, E. L., & Russell, J. M. (1982). The relationship among logical thinking, problem solving instruction, and knowledge and application of earth science subject matter. *Science Education*, 66(1), 85-93.
- Chiu, Mei-Hung (2007). A National Survey of Students' Conceptions of Chemistry in Taiwan. *International Journal of Science Education*, 29(4), 421-452.
- Danili, E., & Reid, N. (2004). Some strategies to improve performance in school chemistry, based on two cognitive factors. *Research in Science & Technological Education*, 22, 201-223.
- Danili, E., & Reid, N. (2006). Cognitive factors that can potentially affect pupils' test performance. *Chemistry Education Research and Practice*, 7(2), 64-83.
- Fryer, M. (1996). *Creative teaching and learning*, London, Paul Chapman.
- Goodenough, D. R., & Karp, S. A. (1961). Field dependence and intellectual functioning. *Journal of Abnormal and Social Psychology*, 63, 241-246.
- Getzels, J. W., & Jackson, P. W. (1962). *Creativity and intelligence*. London/New York: John Wiley.
- Heller, K. A. (2007). Scientific ability and creativity. *High Ability Studies*, 18(2), 209-234.
- Howe, A., & Durr, B. (1982). Using concrete materials and peer interaction to enhance learning in chemistry. *Journal of Research in Science Teaching*, 19, 225-232.
- Hudson, L., (1966). *Contrary Imaginations: a psychological study of the English schoolboy*, Great Britain, Penguin books Ltd.
- Hudson, L., (1968). *Frames of mind*, London, Methuen.
- Hu, L., and P. Bentler. 1999. Cutoff criteria for fit indexes in covariance structure analysis: Conventional criteria versus new alternatives. *Structural Equation Modelling* 6, no. 1: 1-55.
- Hesse, J. J., & Anderson, C. W. (1992). Students' conceptions of chemical change. *Journal of Research in Science Teaching*, 29(3), 277-299.
- Hindal, H., Reid, N., & Badgaish, M. (2009). Working memory, performance and learner characteristics. *Research in Science & Technological Education*, 27(2), 187-204.
- Howe, A., & Durr, B. (1982). Using concrete materials and peer interaction to enhance learning in chemistry. *Journal of Research in Science Teaching*, 19, 225-232.
- Hudson, L. (1966). *Contrary imaginations: a psychological study of the English schoolboy*. Harmondsworth: Penguin.
- Hudson, L. (1968). *Frames of mind*. London: Methuen.
- Johnson, M.A., & Lawson, A.E. (1998). What are the relative effects of reasoning ability and prior knowledge on biology achievement in expository and inquiry classes? *Journal of Research in Science Teaching*, 35(1), 89-103.
- Johnson, P. M. (1998a). Progression in children's understanding of a 'basic' particle theory: A longitudinal study. *International Journal of Science Education*, 20, 393-412.

- Johnson, P. M. (1998b). Children's understanding of changes of state involving the gas state, Part 1. Boiling water and the particle theory. *International Journal of Science Education*, 20, 567–583.
- Johnson, P. M. (1998c). Children's understanding of state involving the gas state, Part 2. Evaporation and condensation below boiling point. *International Journal of Science Education*, 20, 695–709.
- Johnson, P.M. (2000). Children's understanding of substances, part 1: recognizing chemical change. *International Journal of Science Education*, 22(7), 719–737.
- Johnson, P.M. (2002). Children's understanding of substances, part 2: explaining chemical change. *International Journal of Science Education*, 24(10), 1037–1054.
- Johnson, P.M., & Papageorgiou, G. (2010). Rethinking the introduction of particle theory: a substance-based framework. *Journal of Research in Science Teaching*, 47(2), 130–150.
- Johnson, M. A., & Lawson, A. E. (1998). What are the relative effects of reasoning ability and prior knowledge on biology achievement in expository and inquiry classes? *Journal of Research in Science Teaching*, 35(1), 89–103.
- Johnstone, A. H., & Al-Naeme, F. F. (1991). Room for scientific thought? *International Journal of Science Education*, 13(2), 187–192.
- Jöreskog, K.G., and Sörbom, D. 1981. *LISREL V*. Mooresville, IN: Scientific Software
- Jöreskog, K.G., and Sörbom, D. 1996. *LISREL8 user's reference guide*. Chicago: Scientific Software International.
- Jöreskog, K. and Sörbom, D. (1998). *LISREL 8: Structural equation modeling with the SIMPLIS command language*. Chicago: Scientific Software International.
- Kang, S., Scharmann, L.C., Noh, T. & Koh, H. (2005). The influence of students' cognitive and motivational variables in respect of cognitive conflict and conceptual change. *International Journal of Science Education*, 27(9), 1037–1058.
- Kang, S., Scharmann, L. C., Noh, T., & Koh, H. (2005). The influence of students' cognitive and motivational variables in respect of cognitive conflict and conceptual change. *International Journal of Science Education*, 27(9), 1037–1058.
- Kingir, S., Geban, O., & Gunel, M. (2013). Using the science writing heuristic approach to enhance student understanding in chemical change and mixture. *Research in Science Education*, 43(4), 1645–1663.
- Lawson, A., E. (1983). Predicting science achievement: The role of developmental level, disembedding ability, mental capacity, prior knowledge, and beliefs. *Journal of Research in Science Teaching*, 20(2), 117–129.
- Lawson, A.E. (1985). A review of research on formal reasoning and science instruction. *Journal of Research in Science Teaching*, 22, 569–617.
- Lawson, A.E. (1993). *Classroom test of scientific reasoning: Revised paper-pencil edition*. Tempe, AZ: Arizona State University.

- Lee, O., Eichinger, D., Anderson, C., Berkheimer, C., & Blakeslee, T. (1993). Changing middle school students' conceptions of matter and molecules. *Journal of Research in Science Teaching*, 30, 249–270.
- Marsh, H., J. Balla, and R. McDonald. 1988. Goodness-of-fit indexes in confirmatory factor analysis: The effect of sample size. *Psychological Bulletin* 103, no. 3: 391–410.
- Niaz, M. (1996). Reasoning strategies of students in solving chemistry problems as a function of developmental level, functional M-capacity and disembedding ability. *International Journal of Science Education*, 18(5), 525-541.
- Marjoribanks, K. (1978). The relation between students' convergent and divergent abilities, their academic performance, and school-related affective characteristics. *Journal of Research in Science Teaching*, 15, 197-207.
- Nuttall, D. L., (1972). Convergent and divergent thinking. *The British Journal of Educational Psychology*, 43, 1-7.
- Niaz, M. (1996). Reasoning strategies of students in solving chemistry problems as a function of developmental level, functional M-capacity and disembedding ability. *International Journal of Science Education*, 18(5), 525-541.
- Othman, J., Treagust, D. F., & Chandrasegaran, A. L. (2008). An investigation into the relationship between students' conceptions of the particulate nature of matter and their understanding of chemical bonding. *International Journal of Science Education*, 30(11), 1531-1550.
- Ozmen, H. (2004). Some student misconceptions in chemistry: a literature review of chemical bonding. *Journal of Science Education and Technology*, 13(2), 147-159.
- Ozmen, H., & Ayas, A. (2003). Students' difficulties in understanding of the conservation of matter in open and closed system chemical reactions. *Chemistry Education: Research and Practice*, 4(3), 279-290.
- Papageorgiou, G., Grammaticopoulou, M., & Johnson, P.M. (2010). Should we teach primary pupils about chemical change? *International Journal of Science Education*, 32(12), 1647-1664.
- Runco, M. A., (1986). Divergent thinking and creative performance in gifted and non-gifted children. *Educational and Psychological Measurement*, 46, 375-383.
- Sayre, S. & Ball, D., W. (1975). Piagetian cognitive development and achievement in science. *Journal of Research in Science Teaching*, 12 (2), 165-174.
- Schumacker R. & Lomax, R (2010). Structural Equation Modeling: A beginner's Guide, 3rd Edition. Ney York: Routledge.
- Riding, R., & Rayner, S. (1998). *Cognitive styles and learning strategies. Understanding style differences in learning and behaviour*. London: David Fulton.
- Sayre, S., & Ball, D. W. (1975). Piagetian cognitive development and achievement in science. *Journal of Research in Science Teaching*, 12(2), 165-174.
- Skamp, K. (1999). Are atoms and molecules too difficult for primary education? *School Science Review*, 81(295), 87-96.

- Solsona, N., Izquierdo, M., & de Jong, O. (2003). Exploring the development of students' conceptual profiles of chemical change. *International Journal of Science Education*, 25(1), 3-12.
- Stains, M., & Talanquer, V. (2008). Classification of chemical reactions: stages of expertise. *Journal of Research in Science Teaching*, 45(7), 771-793.
- Stamovlasis, D., & Tsaparlis, G. (2005). Cognitive variables in problem solving: A nonlinear approach. *International Journal of Science and Mathematics Education*, 3, 7-32.
- Stamovlasis, D., & Papageorgiou, G. (2012). Understanding Chemical Change in Primary Education: The Effect of two Cognitive Variables. *Journal of Science Teacher Education*, 23(2), 177-197.
- Stamovlasis, D., Tsitsipis, G., & Papageorgiou, G. (2012). Structural equation modeling in assessing students' understanding the state changes of matter. *Chemistry Education, Research and Practice*, 13, 357-368.
- Stamovlasis, D., Papageorgiou, G. & Tsitsipis, G. (2013). The coherent versus fragmented knowledge hypotheses for the structure of matter: An investigation with a robust statistical methodology. *Chemistry Education, Research and Practice*, 14, 485-490.
- Sternberg, R. J. (1997). *Thinking styles*. New York: Cambridge University Press.
- Talanquer, V. (2008). Students' predictions about the sensory properties of chemical compounds: additive versus emergent frameworks. *Science Education*, 92(1), 96-114.
- Tsaparlis, G., & Angelopoulos, V. (2000). A model of problem solving: its operation, validity and usefulness in the case of organic-synthesis problems. *Science Education*, 84, 131-153.
- Tsitsipis, G., Stamovlasis, D., & Papageorgiou, G. (2010). The effect of three cognitive variables on students' understanding of the particulate nature of matter and its changes of state. *International Journal of Science Education*, 32(8), 987-1016.
- Tsitsipis, G., Stamovlasis, D. & Papageorgiou, G. (2012). A Probabilistic Model for Students' Errors and Misconceptions in Relation to Three Cognitive Variables. *International Journal of Science and Mathematics Education*, 10, 777-802.
- Zeitoun, H. H. (1984). Teaching scientific analogies: a proposed model. *Research in Science & Technological Education*, 2, 107-125.
- Zeitoun, H. H. (1989). The relationship between abstract concept achievement and prior knowledge, formal reasoning ability and gender. *International Journal of Science Education*, 11(2), 227-234.

APPENDIX

Description of tasks and items concerning chemical change

Task 1 (<i>Structure</i>): Understanding of the substances structure	
Item 1.	Students are asked to draw the structure of iron and sulfur grains when they observe them using a hypothetical magnifying glass.
Item 2.	Students are asked to explain their previous drawings.
Item 7.	Students are asked to draw the structure of the material after heating, if they can observe it using a hypothetical magnifying glass.
Item 8.	Students are asked to explain their previous drawings.
Task 2 (<i>Changes</i>): Recognition of the substances change	
Item 3.	Students are asked to describe the material before heating (when the two substances are mixed together).
Item 4.	Students are asked to describe the material that is formed after heating.
Item 5.	Students are asked to justify their previous responses concerning descriptions and/or pictures.
Task 3 (<i>Interpretations</i>): Interpretation of the substances change	
Item 6.	Students are asked to answer if the material after heating contains iron and/or sulfur. They are also asked to justify their answer in any case.
Item 9.	Students are asked to explain how the components of this new material are connected to each other justifying its properties.
Item 10.	Students are asked to describe what happens to this material when it started to glow.
Item 11.	Students are asked to describe what happens to this material during the heating and before it started to glow.
